

11384-75-

11435-75

11384-75*

Blacksmith's hand and hammer tools.
Flat cross-longitudinal cutting pliers.
Design and dimensions

11384—65

39 6910

28 1975 . 3679

01.01.77

1982 .

T.

1.1.

. 1 . 1.

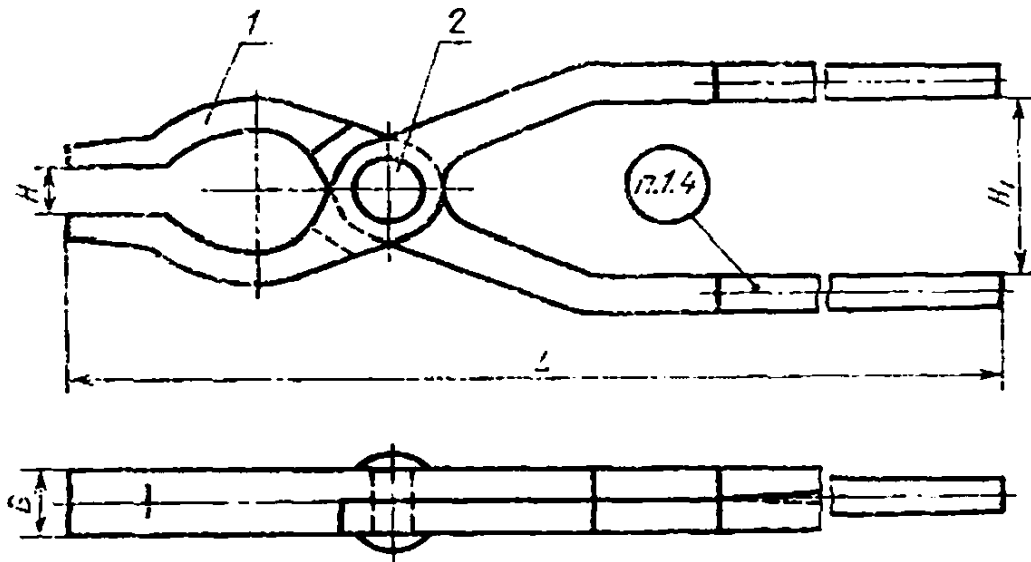

, 1

(1986 .) 1, 1982 . ;
2097 26.05.82 . (9—82)

(S)

, 1987

)

						4J	. /	t
						-	. 1	. 2 10299-80 . 1
							0*03(1)	
1200-0001		12	50	630	20	1,13	1200-0001/001	10X40
1200-0002		16	55		20	1,33	1200-0002/001	
1200-0003		20	60	710	25	2,45	1200-0003/001	12X45
1200-0004		32	70	800	28	3,55	1200-0004/001	12X48

1.2. (1200-0001 =12 : 11384—75)
 1.3. (, — . 1).
 1.4. (— 15 1050—74. 11435—75.)

2. (. 1 }

2.1.

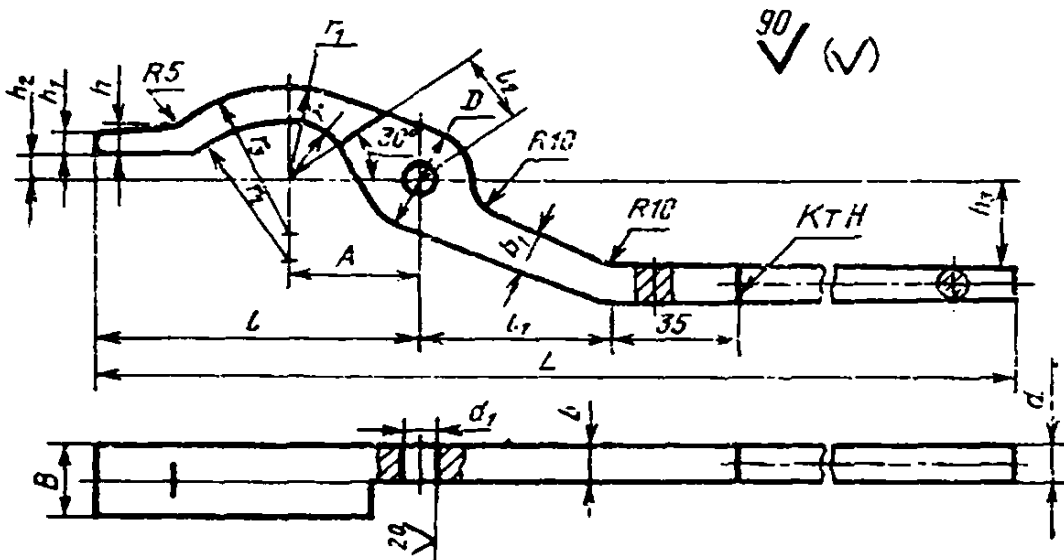

Черт. 2

	*	<i>h</i>	(<i>D</i>	<i>d</i>	(//12)				
1200-0001/001	6	25	7	5	25	9	11	20	10,0	10
1200-0002/001	8	27,5	8	6	28	10				12
1200-0003/001	10	30	9	7	32	1Z	1Q	25	12,5	1
1200-0004/001	16	35	12	10	36			28	14,0	

. 2

	L	<i>l</i>	<i>h</i>	<i>I_ε</i>			<i>ri</i>			
1200-0001/001	630	70	50	20	32	14	25	26	32	0,55
1200-0002/001		90	55	22	36	18	28	42	45	0,65
1200-0003/001	710	110	60	25	40	20	32	45	55	1,20
1200-0004/001	800	160	70	28	55	32	50	90	90	1,75

- = 6 :
 1200-0001/001 11384—75
 2.2. — 45 1050—74.
 2.1, 2.2. (, . 1).
 2.3. ±1 d\ -

2 11384—75

17.12.87 4596

01.07.88

« .1 1.1. 1. .2» . :« .1. .1>
(3 1988 .)